

Introduction

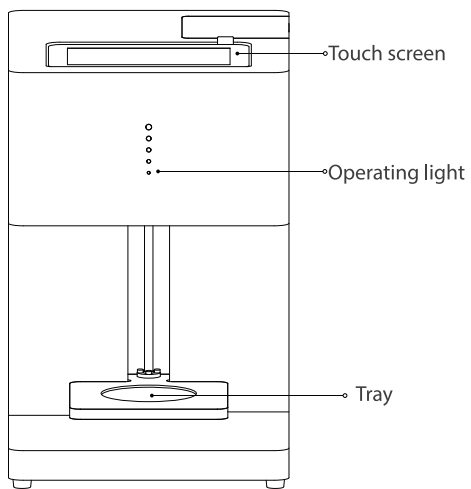

FRONT

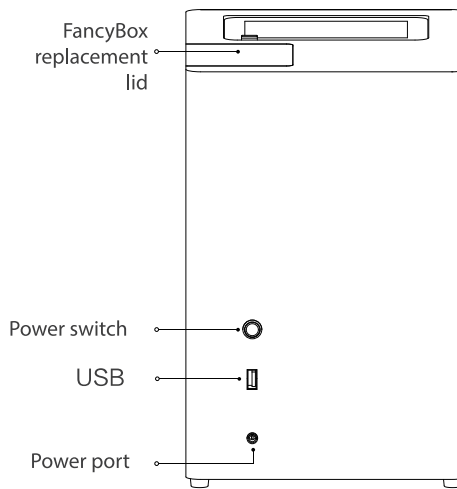

BACK

Preparation

- 1 Open the FancyBox replacement lid and remove the X-axis locking rod,
Please complete the following steps before you use the machine

- ① Open the FancyBox replacement lid
- ② Screw off the locking rod from position A (See Figure 1 below)
- ③ Screw in the locking rod to position B (See Figure 1 below)

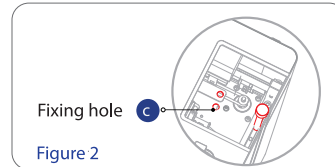
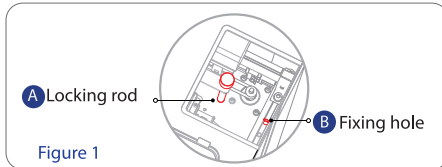

Note: Please screw off the lock rod from position B and screw in it to position C during the course of transportation(See Figure 2 below)

- 2 Connect the machine to the electricity supply (See below Figure 3)

- 3 Install FancyBox

- 4 Connect WiFi

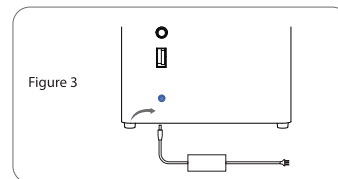

- 5 Obtain the unique machine URL and QR code under Settings Interface

Note: Customer can upload image through this URL or QR code

Usage

- 1 Upload image simply by scanning QR code or input URL
- 2 Select the image and adjust the cup size, image brightness and contrast
- 3 Create high resolution image or text in seconds onto your favorite frothy beverages, both hot and cold

Maintenance

1. Replace FancyBox

Each FancyBox can prints about 800 cups ,you can resume buying through local dealers or our official website: www.evebot-store.com

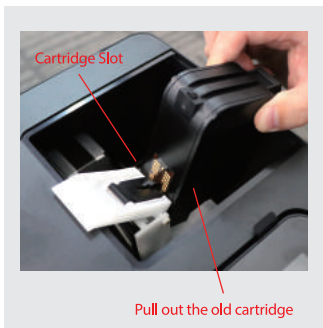

Change the cartridge



Put the new cartridge into slot

2. Daily Clean

This machine does not need complex maintenance, simply wipe clean the tray and surface with a soft damp cloth at the end of each day

Product parameters

Product model	EB-FC1	Electric parameters	AC 100V ~240V 50/60Hz
Outline size	27cm x34cm x 41cm	Cup height	5cm ~ 18cm
Net Weight	12kg	Cup diameter	4cm ~10cm
Network parameters: WiFi 802.11b/g/n		Operating power	18W

Special instructions

Transportation

1. Make sure that remove lock rod from position B and screw in it to position C when transporting
2. Make sure all the cushioning packages have been installation correctly, to avoid transport damage

In use

1. At emergence of an unusual sound, collision , please switch off the device at once

2. If printing pattern failed ,please stop running and take the FancyBox out, wiping the spray-head gently with a tissue, until appear the color
3. Please put the cup in the center of tray, to make the pattern at the cup center
4. Do not use hands or other objects to touch the moving parts, to avoid be involved in when printing

Setting

1. It can not print if the FancyBox do not install correctly
2. Please ensure to place the appliance on a hard, flat level surface

Power Supply

1. Don't twist, don't bend the power cord, differently farewell the cable can remain bared or absolutely break
2. When disconnect the power cord , grasp and pull the connector, not the cord.
3. Please do not connect the cable to the improper socket or other devices
4. Forbid non-specialized person to open the rear cover for maintenance
5. If the power cord becomes lost, damaged , please contact your dealer for a suitable replacement
6. Please disconnect power supply when clean the device

Restrictions in use

Do not use under the below situations , to avoid electric shocks, fire or other damage

1. Easy to dump and other unstable place
2. High temperature and heavy wet place, such as bathroom

Warranty

Warranty terms

1. Evebot will offer a free firmware upgrade service for lifetime
2. Manufacturing defects in materials and workmanship of the product, please contact dealer for repair or replacement
3. Evebot will provide a 12 month warranty, during the warranty period, if any accessory defect is inspected and confirmed by dealer, a free replacement service shall be provided.
4. The Limited Warranty starts from the day the customer receives the product.

No-warranty terms

1. Expired warranty
2. Damages caused by force majeure
3. Violations against warranty, including but not limited to customer induced damage, such as self-repairs, exposure to water, damage caused by misuse, alternation, failure to comply with product manual, and so on.